

**MSO70000, DPO7000, DPO70000, DSA70000,
DPO70000B and DSA70000B
High Performance Oscilloscopes
Best Practices Manual**



071-2745-00

Tektronix

**MSO70000, DPO7000, DPO70000, DSA70000,
DPO70000B and DSA70000B
High Performance Oscilloscopes
Best Practices Manual**

Copyright © Tektronix. All rights reserved. Licensed software products are owned by Tektronix or its subsidiaries or suppliers, and are protected by national copyright laws and international treaty provisions.

Tektronix products are covered by U.S. and foreign patents, issued and pending. Information in this publication supersedes that in all previously published material. Specifications and price change privileges reserved.

TEKTRONIX and TEK are registered trademarks of Tektronix, Inc.

Contacting Tektronix

Tektronix, Inc.
14200 SW Karl Braun Drive
P.O. Box 500
Beaverton, OR 97077
USA

For product information, sales, service, and technical support:

- In North America, call 1-800-833-9200.
- Worldwide, visit www.tektronix.com to find contacts in your area.

Best Practices for Using High Performance Oscilloscopes

Optimizing and maintaining the performance of your Tektronix product is critical to your success. This document summarizes the Best Practices for using Tektronix MSO70000, DPO7000, DPO70000, DSA70000, DPO70000B and DSA70000B Series products. Additional technical, application, and service information is available at the www.tektronix.com Web site.

Preventing Electrostatic Discharge

Electrostatic discharge (ESD) is a concern when handling any electronic equipment. All Tektronix instruments and probes are designed with robust ESD protection. However, large discharges of static electricity applied to the signal inputs may damage the equipment.



CAUTION. A direct static discharge can damage the input circuitry of the instrument. To avoid damage, follow these techniques to prevent electrostatic discharge to the instrument:

1. Discharge the static voltage from your body. To do so, wear a grounded antistatic wrist strap when you connect and disconnect cables and adapters. Your instrument provides a convenient ground connection on the front panel for this purpose.

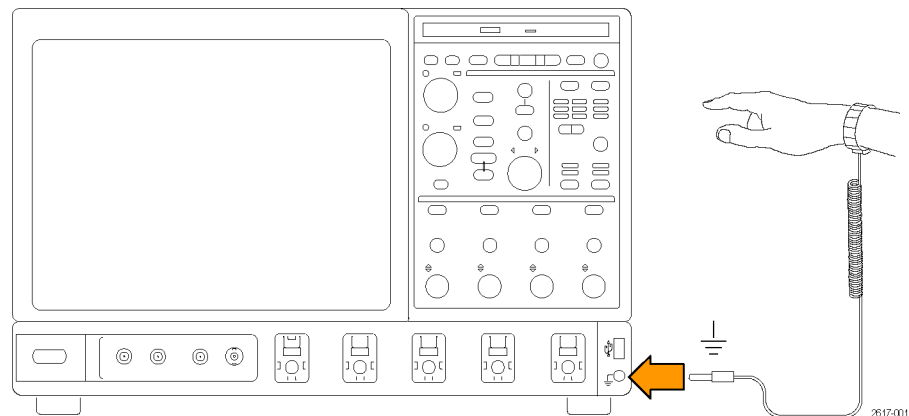

2. Discharge the static voltage from all cables before connecting them to the instrument or to the device under test (DUT). Before you attach the cable to the instrument, you can momentarily ground the center conductor of the cable, or you can connect a 50 ohm termination to one end prior to attaching the cable to the instrument.

NOTE. A cable that is left unconnected on a bench can develop a very large static charge that can damage the instrument.

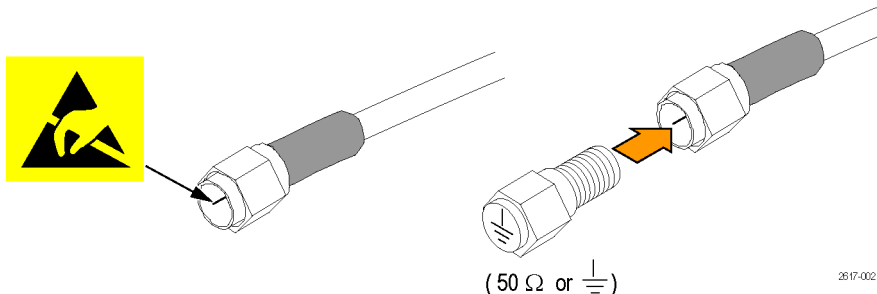

Signal Path Compensation and Instrument Calibration

Signal Path Compensation (SPC) corrects for DC inaccuracies caused by temperature variations or by long-term drift. Remove all channel input connections and run the SPC routine whenever the ambient temperature of the instrument has changed by more than 5 °C (9 °F), or once a week to assure that acquisitions are made with a high degree of accuracy.



CAUTION. Remove all channel input signals when running SPC or diagnostics as input signals may interfere with calibration. On DPO7000 Series instruments, applying more than 5 V during these processes or during power on will cause calibration or diagnostics to fail and may damage the instrument.

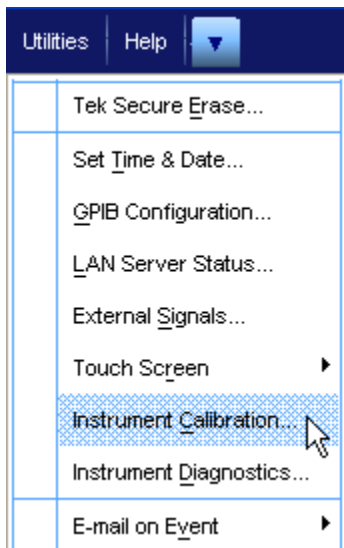

Adhere to a regular schedule of calibration of the instrument. A Tektronix Calibration Service plan is the most efficient way to ensure specified performance over the lifetime of your Tektronix instrument. The service plan also guarantees continuous compliance with international quality and traceability standards. You can contact your Tektronix Representative or refer to the www.tektronix.com Web site for instrument calibration services.

Instrument Temperature and Clearance

The instrument must have 3 inches of clearance on both the left and right sides for proper ventilation. The air temperature around the instrument must be between +5 °C and +45 °C (+41 °F and +113 °F).

Deskew Channels

Use the Deskew/Attenuation control window to compensate for propagation delays of different length probes and to set the input/output ratio of any external attenuation or gain between the signal and input channels. Deskew relates directly to the vertical settings, so it is important to deskew at the vertical settings at which measurements will be taken or within the same amplifier range (such as, from 50 to 99 mV/div, or from 100 to 200 mV/div). Refer to the Deskew/Attenuation Control Window topic in the Online Help of the instrument for information on the deskew and attenuation procedures.

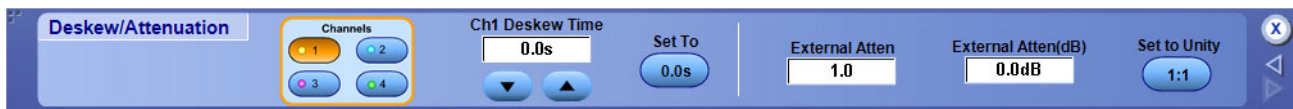
**Operating System Restore Back-up Media**

The packaging of new oscilloscopes comes with instructions to create an Operating System (OS) Restore DVD or CDs. If your instrument did not include an OS Restore DVD, use these instructions at your earliest opportunity to make CDs or a DVD of the OS Restore software, and keep the back-up media in a location in which it will be easily locatable by authorized users of the instrument. If the instructions are lost, contact Tektronix Technical Support for assistance.

Updates to Firmware and Applications

You should regularly check for updates to the instrument firmware and applications of your Tektronix products. You can access the www.tektronix.com/software Web page and search for the model number of your instrument (or application) to check for updates.

Windows Applications and Hard Drive Maintenance

The Windows instrument is highly specialized to execute the oscilloscope application that is its primary function. It also provides the capability to run other Windows compatible applications in the Windows Desktop. Some 3rd Party applications (not from Tektronix) are included with the Windows instrument for your convenience, such as CD creation and/or Virus Scan programs. Caution should be taken when adding new 3rd Party programs to the Windows instrument so that the 3rd Party program will not interfere with the operation of the primary oscilloscope application and its supporting software architecture.

The same practices that are recommended for maintenance of personal computer hard drives also apply to maintenance of the Windows instrument local hard drive. You need to defragment the hard drive every 6 months or more often, depending on how much data is stored on it.

Instrument Power On



CAUTION. Remove all channel input signals when running SPC or diagnostics as input signals may interfere with calibration. On DPO7000 Series instruments, applying more than 5 V during these processes or during power on will cause calibration or diagnostics to fail and may damage the instrument.

Windows Shut Down Procedures

The Windows instrument has specialized shut down procedures that assure the integrity of the system structure and data when powering down the instrument. Use the Shutdown command in the File menu of the oscilloscope, or the Shut Down command in the Start menu when powering down the instrument. Avoid abrupt shutdowns caused by pushing the On/Standby button for 5 seconds or by removing the power cable.

Allow the instrument to complete its Start-up routine before shutting down the oscilloscope. Do not power down the instrument before the Windows system is fully loaded and running, as this action will harm the Windows System files.

Taking Acquisitions and Measurements

Here are suggestions from Tektronix Application Engineers on the best practices to follow when you take measurements:

- Make sure that the cables are capable of the bandwidth that is being measured.
- Torque the SMA connectors to 8 in-lbs for proper power measurements.
- Tighten the screw on high bandwidth probes and on the TCA-292 to avoid connector float that can disturb the signal.
- Push the Default Setup button to begin from a known state when configuring the instrument for the acquisition.
- Verify that the signal is properly characterized by using the highest Horizontal Resolution possible.
- Verify that the signal is maximized from the bottom of the screen to the top of the screen.
- Use the Fine adjustment with the Vertical controls to get the best resolution.
- Use a constant sample rate if the acquisition needs to be at the full sample rate as the timebase is adjusted.
- Check the surrounding environment of the instrument for interfering signal sources.
- Keep the lead lengths between the DUT and the instrument input connector as short as possible.
- Save relevant waveform data files and screen shots to allow you to go back and verify measurements.

Maximum Instrument Input Voltage

The maximum instrument input voltages are as follows:

MSO70000, DPO70000, DSA70000, DPO70000B and DSA70000B Series

10 mV/div to 99.5 mV/div: 1 V_{RMS}

100 mV/div to 1 V/div: 5 V_{RMS}

DPO7000 Series

1 M Ω : ± 150 V CAT I, derate at 20 dB/decade to 9 V_{RMS} above 200 kHz

50 Ω : 5 V_{RMS} with peaks less than ± 24 V

NOTE. When using probes on the measurement inputs, do not exceed the instrument or probe ratings. Refer to the user manual for additional information available on the www.tektronix.com/manuals Web page.



CAUTION. Remove all channel input signals when running SPC or diagnostics as input signals may interfere with calibration. On DPO7000 Series instruments, applying more than 5 V during these processes or during power on will cause calibration or diagnostics to fail and may damage the instrument.

Best Practices for Using Probes

For P7500 Series probes, the maximum non-destructive input voltage is: ± 15 V (DC + peak AC).



CAUTION. To avoid damage to the probe inputs, do not apply more than ± 15 V (DC + peak AC) between each input, or between either probe input and ground.

Refer to the probe user or instruction manual for additional information available on the www.tektronix.com/manuals Web page.

ESD and Probes

To avoid ESD damage to the probe, always use an antistatic wrist strap and work at a static-approved workstation when you handle the probe. (See page 1, *Preventing Electrostatic Discharge*.)

P7500 Series TriMode Probes

Dynamic Range. The differential signal ranges (with DC coupled) are as follows:

P7513 and P7516	P7520
± 0.750 V at 5X attenuation	± 0.625 V at 5X attenuation
± 1.75 V at 12.5X attenuation	± 1.60 V at 12.5X attenuation

The operating voltage window (shown next) defines the maximum voltage that you can apply to each input, with respect to earth ground, without saturating the probe input circuitry. A common-mode voltage that exceeds the operating voltage window may produce an erroneous output waveform, even when the differential-mode specification is met.

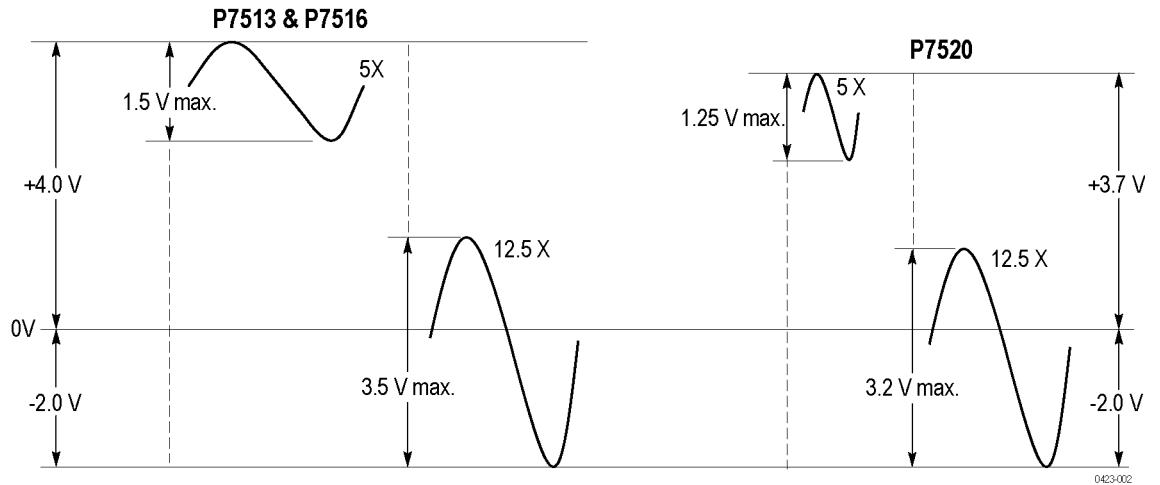

Offset Voltage Range. The offset voltage ranges are as follows:

P7513, P7516, and P7520
-1.5 V to +2.5 V for Differential mode
P7513, P7516
-2.0 V to +4.0 V for Single-Ended and Common mode (ground referenced)
P7520
-1.8 V to +3.4 V for Single-Ended and Common mode (ground referenced)

The Offset Voltage Control, accessible from the attached instrument, allows the probe dynamic range to be effectively moved up and down within the limits of the offset voltage range and the operating voltage window. When the offset voltage is set to zero volts and the input signal is zero volts (analog channel inputs shorted to ground, not open), the displayed signal should be zero volts. If a noticeable zero volt offset is present under the above conditions, a Probe Cal operation should be performed. (See the *P7500 Series Probes Quick Start User Manual*.)

Soldering

To prevent damage to the circuit board or circuit board connections due to accidental movement of the probe and soldered leads, we recommend that you secure the tip to the circuit board using the adhesive tip tape provided in your accessory kit. You can also use other materials such as Kapton tape or hot glue. To avoid damage to the tip or to the circuit under test, avoid applying excessive heat from the soldering iron. Use a low wattage, temperature-controlled soldering iron and appropriately sized soldering iron tip.

You need to follow these precautions when you solder the tips:

- For best soldering results, use a microscope to examine the quality of the solder joints.
- Use a low-wattage, temperature-controlled soldering iron and a small-mass soldering iron tip. The soldering iron temperature should be set as low as possible, while still providing a reliable solder joint.
- Use SAC305 solder (included with the P7500 wire replacement kit) to attach the tip wires to the DUT.
- When replacing tip wires or axial-lead resistors, use solder wick to remove the excess solder from the probe tip circuit board via holes. Be careful not to overheat the via and damage the board.
- The attachment wires should be bent symmetrically to vary the interconnect spacing. Use care when you solder a tip to a DUT to avoid inadvertently desoldering either the attachment wires or the damping resistor.
- For optimum performance and signal integrity, keep the lead length between the DUT and the tip as short as possible, and the lead lengths the same length.

Precautions When Handling Probe Cables

Tektronix P6700, P7300, and P7500 Series probes are quality measurement tools and should be treated with care to avoid damage or performance degradation due to mishandling. Be sure to follow these precautions when handling any probe cables.

- Do not excessively pull or twist the probe cables when positioning the probe for measurements.
- Never crush the cable, as might occur when you run over the probe with a chair wheel or drop something heavy on the cable.
- To maximize probe life, limit the amount of cable twist relative to the probe control box to ± 180 degrees. Always uncoil a probe cable gently before applying the twisting forces needed to orient the probe head for connection to the probe tip.

Be sure to follow these additional precautions when handling P7500 Series probe cables:

- Never over-bend the probe main or tip cables, which can put a permanent kink into the cable. When storing the probe, do not coil it too tightly. It is best to use the protective foam carrying case which is designed to not exceed the minimum bend radius of 2.5 inches.

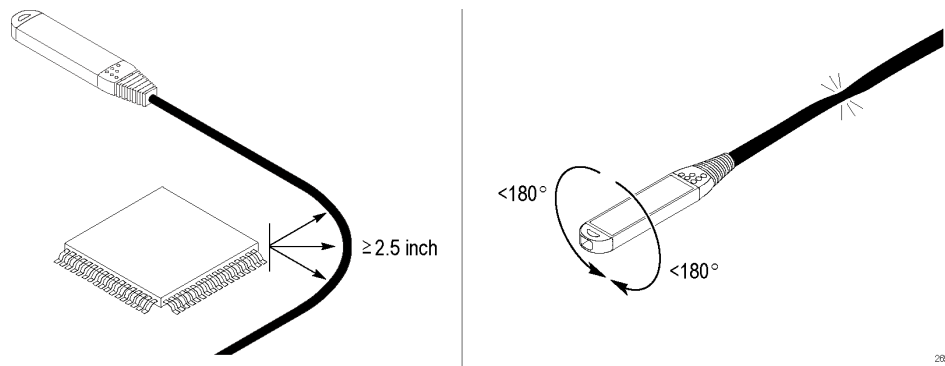

2007-001

Be sure to follow these additional precautions when handling P6700 Series probe cables:

- Never over-bend the probe main or tip cables, which can put a permanent kink into the cable. When storing the probe, do not coil it too tightly. Do not exceed the minimum bend radius of 1 inch for either cable.
- Do not exceed the minimum bend radius of 2.5 inches side-to-side with a probe main cable laying flat.

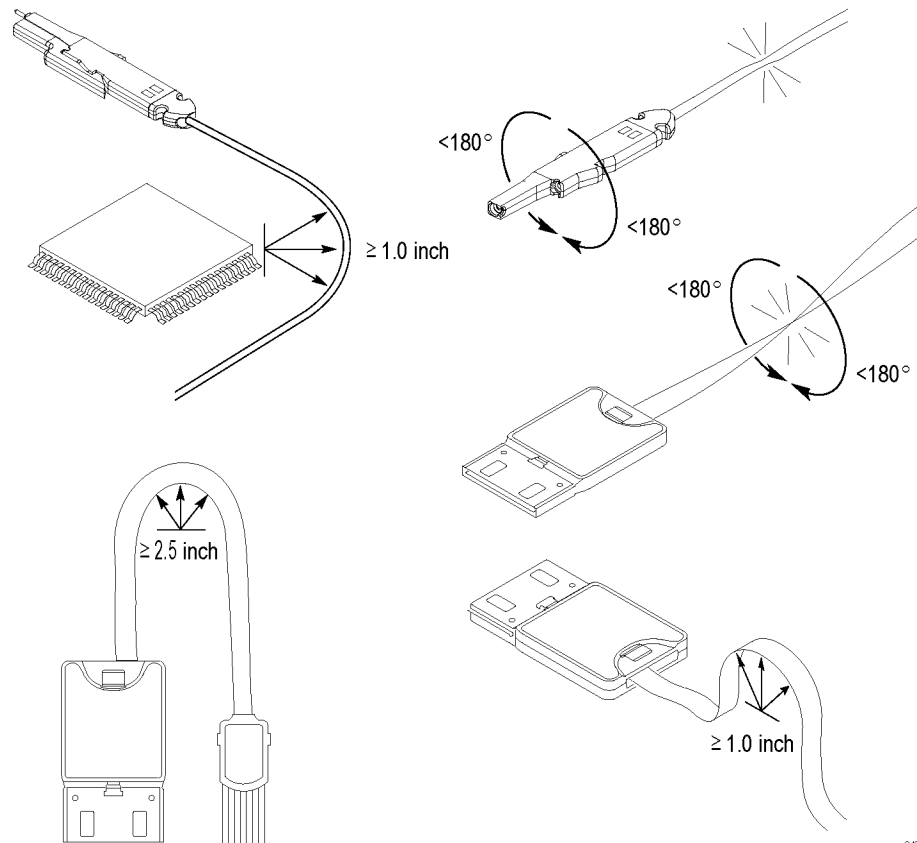

Maintenance of P7500 Probes

The input to the probe body, the part of the probe that connects to the various tips, was designed with replaceable G3PO RF bullets. These RF bullets are similar in function to SMA barrel connectors. Since the P7500 Series probes can be used with multiple interchangeable tips, there is the possibility of wearing out or damaging the input connector. To address this issue, you can replace the RF bullets.

The bullet contacts in the probe body should be replaced every 200 insertion cycles. For medium use situations, this should be about once a year.

Remove Bullets. To remove the bullets, use the removal tool (Tektronix part number: 003-1896-00) and follow these steps:

1. Squeeze the tool plunger to extend the holder tangs.
2. Insert the removal tool into the probe body so that the holder tangs surround one of the bullets.
3. Release the plunger to secure the holder tangs on the bullet.
4. Gently pull the tool outward to remove the bullet.
5. Repeat for the other bullet.



CAUTION. *If you cannot extract the bullets with the bullet removal tool, you can use fine needle-nosed pliers and a magnifying glass or microscope. Be careful not to damage the probe body with the pliers.*

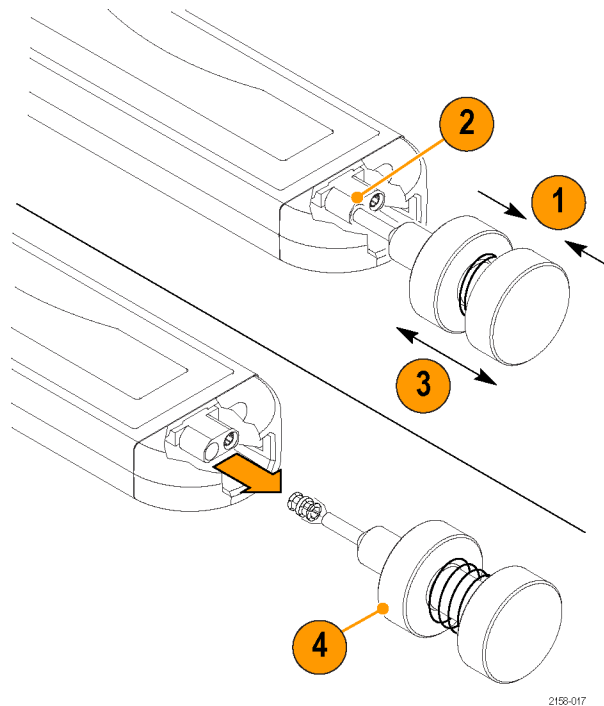

Install Bullets. When both bullets have been removed, you can install new bullets. To do so, follow these steps:

1. Squeeze the tool plunger to extend the holder tangs.
2. Insert a new bullet into the tool so that the holder tangs surround the bullet.
3. Release the plunger to secure the holder tangs on the bullet.
4. Insert the tool into the probe body and seat the bullet in the recess.
5. Squeeze the tool plunger to release the bullet.
6. Gently pull the tool out of the probe body.
7. Repeat for the other bullet.
8. Test that the bullets are installed correctly by connecting and then removing an accessory solder tip to the probe head. Inspect the probe head and verify that the bullets remain seated in the probe head.

